

THIS DOCUMENT IS SUBJECT TO CHANGE WITHOUT NOTICE. IT IS CONFIDENTIAL AND A PROPERTY OF Amphenol LTW. DISCLOSURE TO THIRD PARTY HAS TO BE AUTHORIZED BY Amphenol LTW.

REV.	ECN NO.	DATE	SIGN	DESCRIPTION
A		2021-05-05	Allen Pan	Rev.01 To Rev.A
B	C221759	2022-11-14	Allen Pan	B x2
C	C240789	2024-07-08	Timothy	C x3

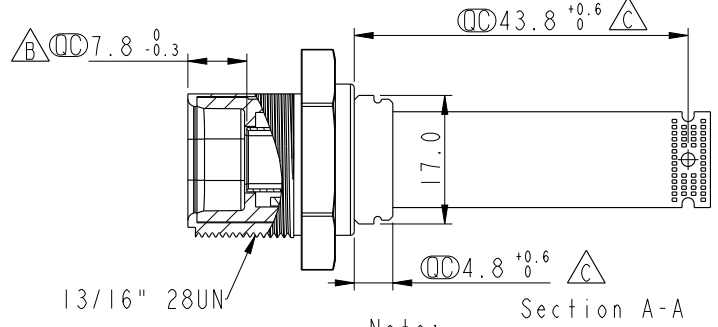
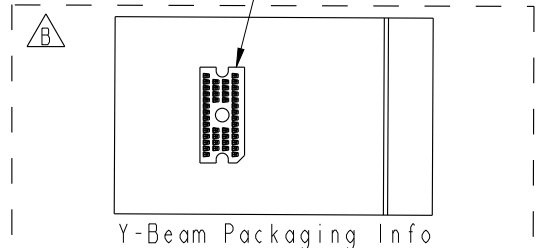
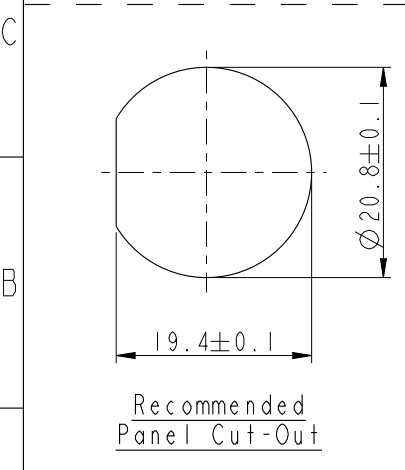
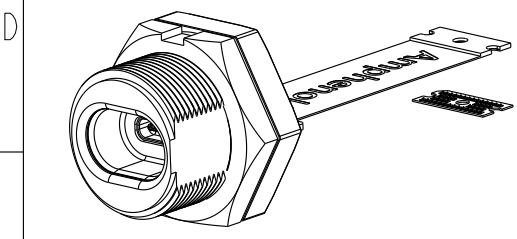
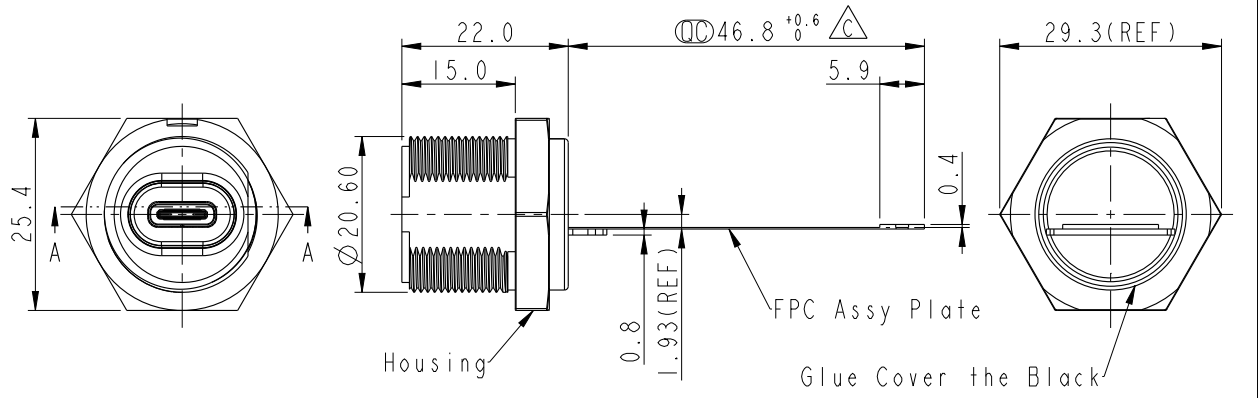
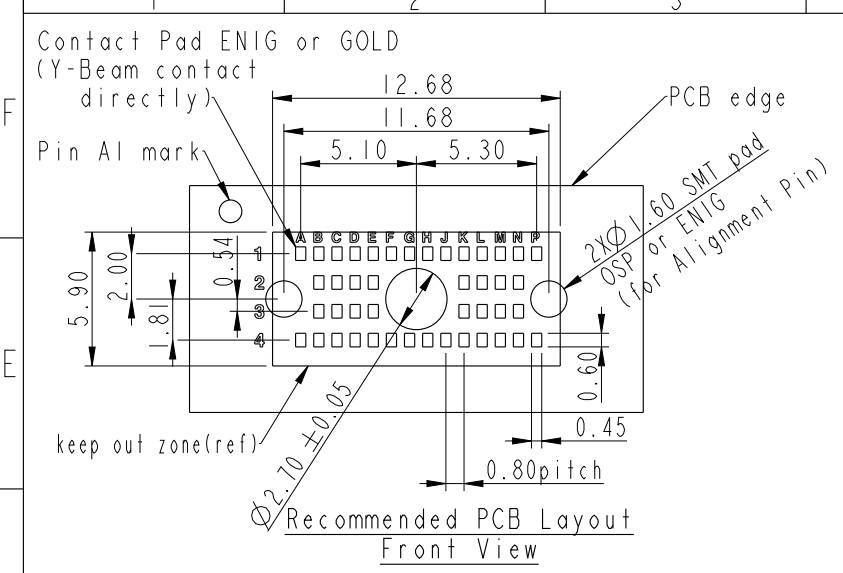

- Note:
- * RoHS Compliant
 - * \varnothing Important Dimension
 - * Waterproof Rate: IPX7, Unmated
 - * Connector: USB Type C Female
 - Housing: Thermoplastic, Black
 - * Shield/Nut: Metal
 - * O-Ring: Rubber, Gray
 - * For Panel Thickness Max: 4.0mm
 - * Recommended Nut Torque: 4-6kgf.cm.
 - * O-Ring and Nut are assembled on connectors

	A	B	C	D	E	F	G	H	J	K	L	M	N	P
1	GND	GND	SBU1	SBU2	GND	Vbus	Vbus	Vbus	Vbus	GND	CC1	CC2	GND	GND
2		GND	TX1+	TX1-	Vbus					Vbus	RX2-	RX2+	GND	
3		RX1+	RX1-	GND	Vbus					Vbus	GND	TX2-	TX2+	
4	Shield	GND	GND	D+	D-	Vbus	Vbus	Vbus	Vbus	Vbus	GND	GND	GND	Shield

PCB Pin Assignment

UNIT: mm		
TOLERANCE	.X ±0.25	
.XX ±0.1		
.XXX ±0.05		
ANGLES	±1°	

TITLE USB, C TYPE SHLD, FRONT FASTENED M, F, Y-BEAM, SCREW			
SCALE 1:1	SIZE A4	SHEET 1 OF 2	
REV. C	WC-REV. A.2	\varnothing : Inspection item	

Amphenol LTW
安費諾亮泰企業股份有限公司

ITEM NO. USC-00PMFY-SC7001	DRAWN BY Timothy	DATE 2024-07-08
DWG NO. USC-00PMFY-SC7001	CHECKED BY Jerry	DATE 2024-07-08
CUSTOMER ALTW	APPROVED BY Fred	DATE 2024-07-08

THIS DOCUMENT IS SUBJECT TO CHANGE WITHOUT NOTICE. IT IS CONFIDENTIAL AND A PROPERTY OF AMPHENOL LTW. DISCLOSURE TO THIRD PARTY HAS TO BE AUTHORIZED BY AMPHENOL LTW.

2 3 4 5 6 7 8

F

E

D

C

B

A

Shell	Ground (GND)	P4, A4
A1, B1, A12, B12	Ground (GND)	P1, N1, K1, E1, B1, A1 N2, B2 L3, D3 N4, M4, L4, C4, B4
A4, B4, A9, B9	VBUS	J1, H1, G1, F1 K2, E2 K3, E3 K4, J4, H4, G4, F4
A2	SSTXp1	C2
A3	SSTXn1	D2
A5	CC1	L1
A6	Dp1	D4
A7	Dn1	E4
A8	SBU1	C1
A10	SSRXn2	L2
A11	SSRXp2	M2
B2	SSTXp2	N3
B3	SSTXn2	M3
B5	CC2	M1
B6	Dp2	D4
B7	Dn2	E4
B8	SBU2	D1
B10	SSRXn1	C3
B11	SSRXp1	B3
USB	Signal Assignment	FPC
Pin Map		

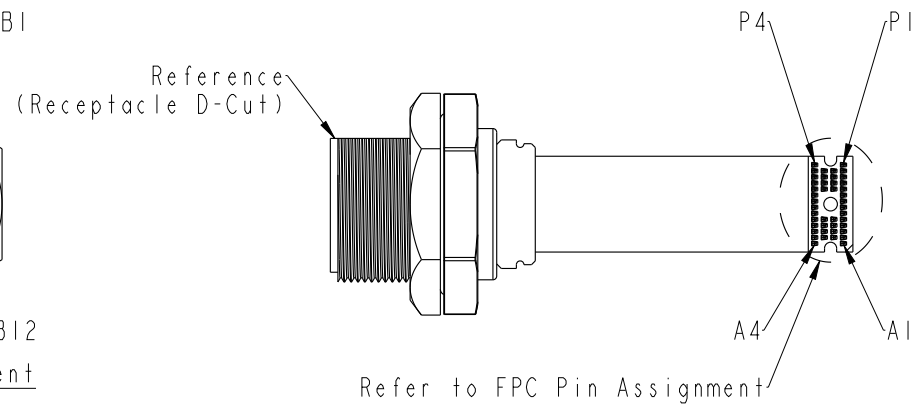
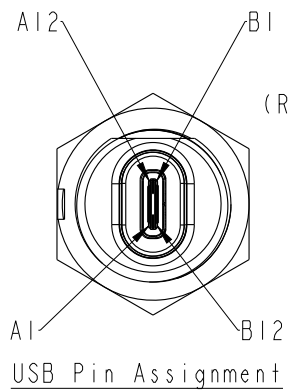

	P	N	M	L	K	J	H	G	F	E	D	C	B	A
1	GND	GND	CC2	CC1	GND	Vbus	Vbus	Vbus	Vbus	GND	SBU2	SBU1	GND	GND
2		GND	RX2+	RX2-	Vbus					Vbus	TX1-	TX1+	GND	
3		TX2+	TX2-	GND	Vbus					Vbus	GND	RX1-	RX1+	
4	Shield	GND	GND	GND	Vbus	Vbus	Vbus	Vbus	Vbus	D-	D+	GND	GND	Shield

FPC Pin Assignment

UNIT: mm		
TOLERANCE	.X ±0.25	
.XX	±0.1	
.XXX	±0.05	
ANGLES	±1°	

TITLE USB, C TYPE SHLD, FRONT FASTENED M, F, Y-BEAM, SCREW			
SCALE 1:1	SIZE A4	SHEET 2 OF 2	
REV. C	WC-REV. A.2	☉: Inspection item	

Amphenol LTW
安費諾亮泰企業股份有限公司

ITEM NO USC-00PMFY-SC7001	DRAWN BY Timothy	DATE 2024-07-08
DWG NO USC-00PMFY-SC7001	CHECKED BY Jerry	DATE 2024-07-08
CUSTOMER ALTW	APPROVED BY Fred	DATE 2024-07-08

2 3 4 5 6 7 8