

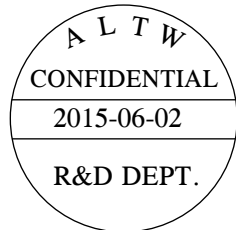

REV.	ECN NO.	DATE	SIGN	DESCRIPTION
B	LEN1570062	2015/06/02	Ruru	Change Logo

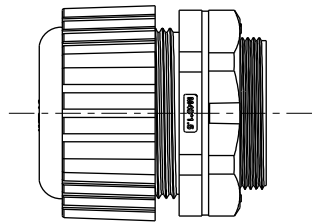
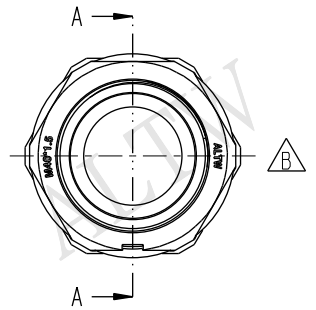
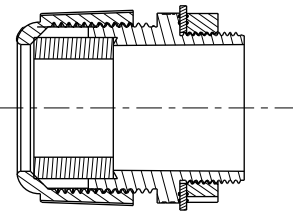
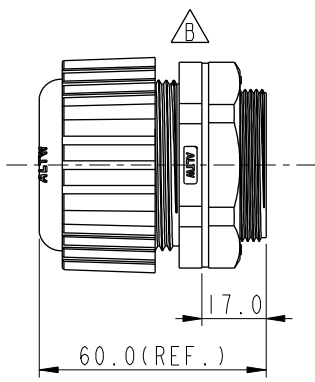
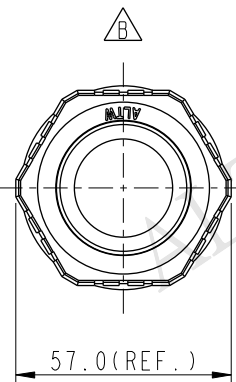
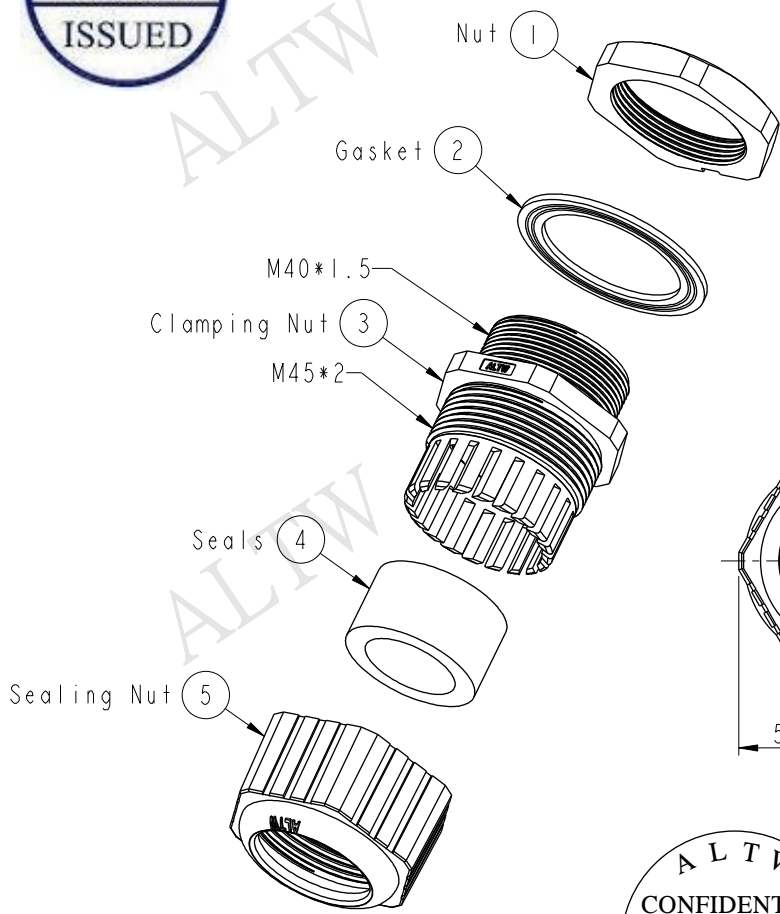

- Note:
- * Waterproof Rate: IP68
 - * Screw Nut: Nylon, Gray
 - * Clamp Ring: Nylon, Gray
 - * Sealing Nut: Nylon, Gray
 - * Gasket: EPDM, Black
 - * Seals: EPDM, Black
 - * For Panel Thickness: 9.0mm max
 - * Cable Range: $\varnothing 20 \sim \varnothing 25$ mm
 - * Spanner Size:
 - Body: 50.3mm
 - Sealing Nut: 51.7mm
 - Screw Nut: 50.0mm

UNIT:mm		
TOLERANCE		
±0.5 mm		

TITLE Cable Gland Assembly(M40*1.5)			
SCALE 1:2	SIZE A4	SHEET 1 OF 1	
REV. B	WC-REV. A.1	QC: Inspection item	

Amphenol LTW
安費諾亮泰企業股份有限公司

ITEM NO CSG-40M002	DRAWN BY Ruru	DATE 2015-06-02
DWG NO CSG-40M002	CHECKED BY Rita	DATE 2015-06-02
CUSTOMER ALTW	APPROVED BY Lion	DATE 2015-06-02

THIS DOCUMENT IS SUBJECT TO CHANGE WITHOUT NOTICE. IT IS CONFIDENTIAL AND A PROPERTY OF AMPHENOL LTW. DISCLOSURE TO THIRD PARTY HAS TO BE AUTHORIZED BY AMPHENOL LTW.