

THIS DOCUMENT IS SUBJECT TO CHANGE WITHOUT NOTICE. IT IS CONFIDENTIAL AND A PROPERTY OF Amphenol LTW. DISCLOSURE TO THIRD PARTY HAS TO BE AUTHORIZED BY Amphenol LTW.

REV.	ECN NO.	DATE	SIGN	DESCRIPTION
B	LEN-8B0475	2008/09/17	Shin	Add Note and Update Drawing to New Format
C	LEN1530184	2014/12/19	Ruru	Change Logo
D	CI90274	2019/02/20	Ruru	Modify Note

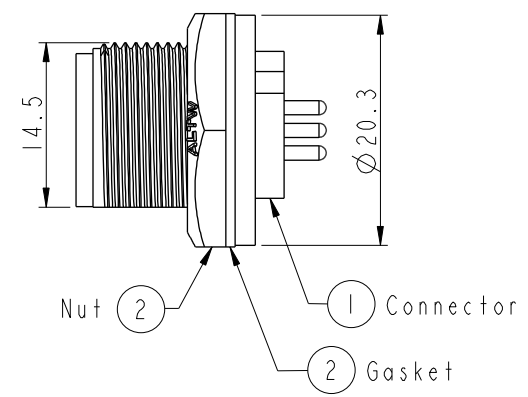
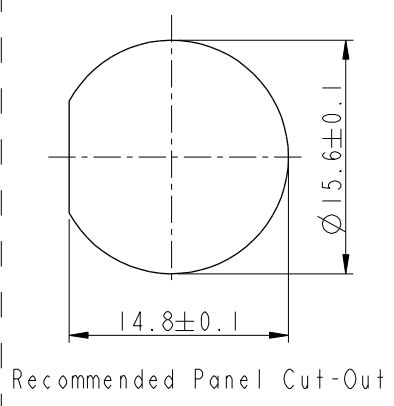
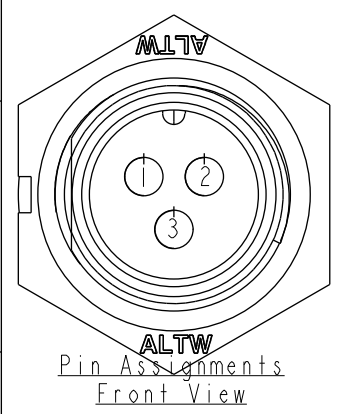
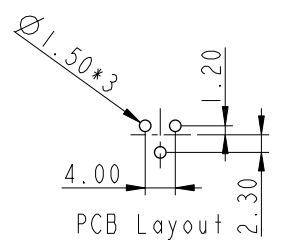
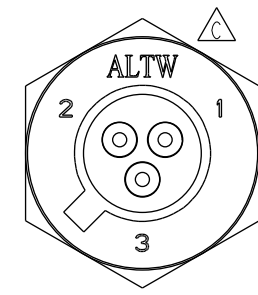
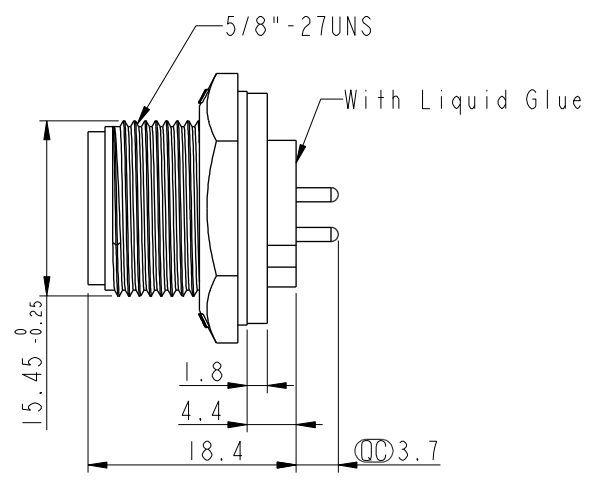
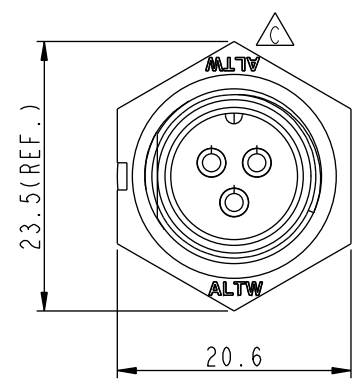

- Note:  $\triangle$
- \*  $\text{CC}$  Important Dimensions To Check.
  - \* Waterproof Rate: IP67, Unmated
  - \* Housing: Thermoplastic, Black
  - \* Pin: Copper Alloy, Gold Plated
  - \* Nut: Thermoplastic, Black
  - \* Gasket: Rubber, Black
  - $\triangle$  \* Use with Waterproof Cap or Dustcap  
Panel Thickness Max: 3.0mm
  - $\triangle$  \* Use without Waterproof Cap or Dustcap  
Panel Thickness Max: 4.0mm
  - \* Gasket and Nut are packed separately in PE bags.

UNIT: mm

TOLERANCE	
.X	±0.25
.XX	±0.1
.XXX	±0.05
ANGLES	±1°

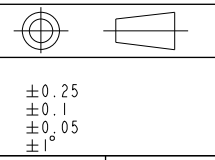

TITLE Standard, Panel Screw 3Pin M Conn M Pin			
SCALE 1:1	SIZE A4	SHEET 1 OF 1	
REV. D	WC-REV. A.3	$\text{CC}$ : Inspection item	

**Amphenol LTW**  
安費諾亮泰企業股份有限公司

ITEM NO. BB-03PMMP-SC7001	DRAWN BY Ruru	DATE 2019-02-20
DWG NO. BB-03PMMP-SC7001	CHECKED BY Rita	DATE 2019-02-20
CUSTOMER ALTW	APPROVED BY Max	DATE 2019-02-20

DATE 2019-02-20
DATE 2019-02-20
DATE 2019-02-20