

| REV. | ECN NO. | DATE | SIGN | DESCRIPTION |
|------|------------|------------|------|-------------|
| B | LEN1560159 | 2015/05/15 | Ruru | Change Logo |
| | | | | |

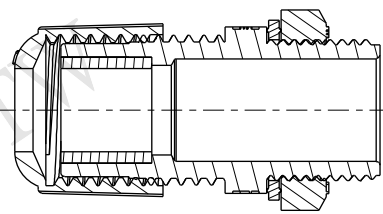

Section A-A

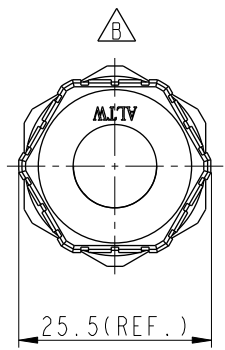
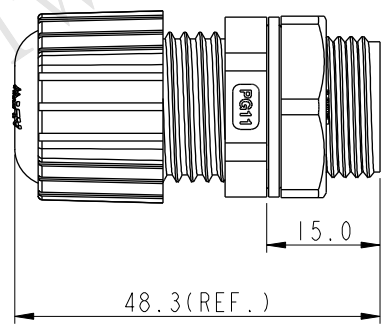
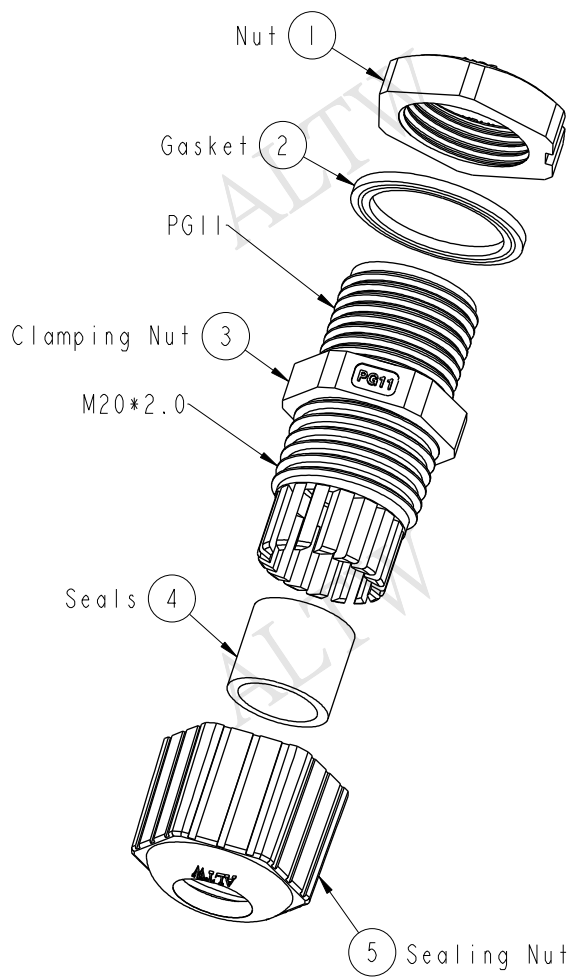
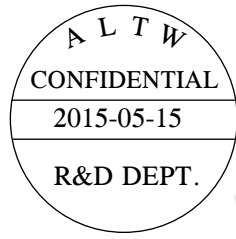
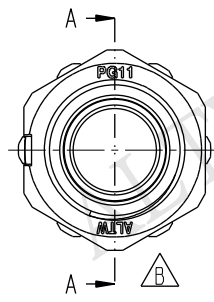

- Note:
- * Waterproof Rate: IP68
 - * Screw Nut: Nylon, Black
 - * Clamp Ring: Nylon, Black
 - * Sealing Nut: Nylon, Black
 - * Gasket: EPDM, Black
 - * Seals: EPDM, Black
 - * Cable Range: $\varnothing 6.0 \sim \varnothing 10.0$ mm
 - * For Panel Thickness: 6.0mm max
 - * Spanner Size:
 - Body: 22.0mm
 - Sealing Nut: 22.9mm
 - Screw Nut: 24.0mm

| | | |
|-----------|--|--|
| UNIT: mm | | |
| TOLERANCE | | |
| ±0.5 mm | | |

| | | | |
|----------------------------|----------------|---------------------|--|
| TITLE PG11 Cable Glands | | | |
| SCALE 1:1 | SIZE A4 | SHEET 1 OF 1 | |
| REV. B | WC-REV. A.3 | QC: Inspection item | |

Amphenol LTW
安費諾亮泰企業股份有限公司

| | | |
|-----------------------|---------------------|--------------------|
| ITEM NO CSG-11G001 | DRAWN BY Ruru | DATE 2015-05-15 |
| DWG NO CSG-11G001 | CHECKED BY Rita | DATE 2015-05-15 |
| CUSTOMER ALTW | APPROVED BY Lion | DATE 2015-05-15 |

THIS DOCUMENT IS SUBJECT TO CHANGE WITHOUT NOTICE. IT IS CONFIDENTIAL AND A PROPERTY OF Amphenol LTW. DISCLOSURE TO THIRD PARTY HAS TO BE AUTHORIZED BY Amphenol LTW.