

REV.	ECN NO.	DATE	SIGN	DESCRIPTION
A	Initial Release	2012/10/22	Ruru	LD20-12PMFS-SS8001 To LD20-12PMFS-SW8001
B	LE31650236	2016/05/04	Vicky	Update Note

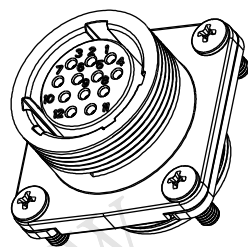
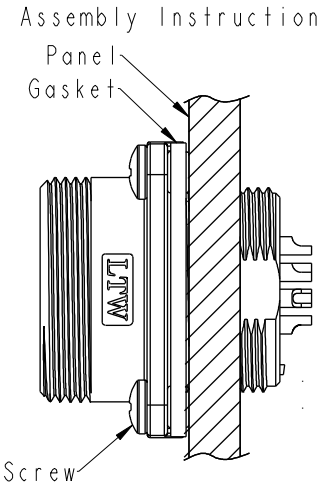
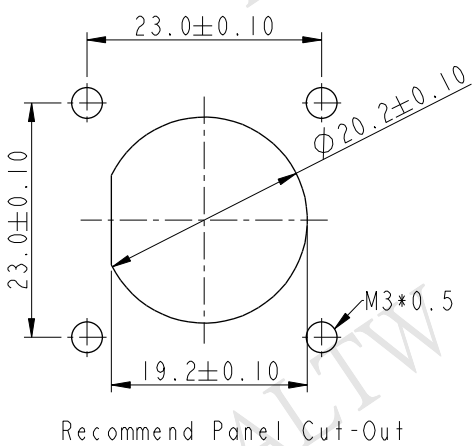
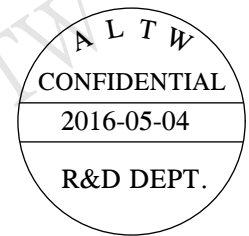
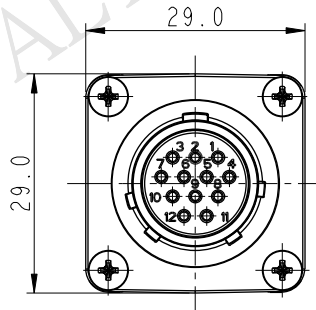
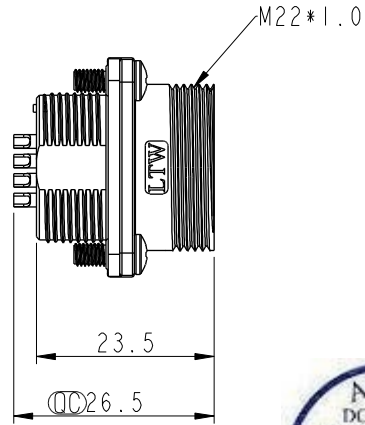
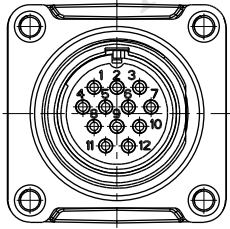
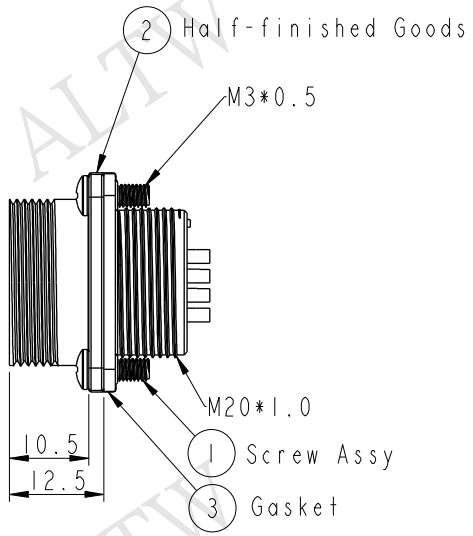

- Note:**
- \*  $\varnothing$  Important Dimension.
  - \* Waterproof Rate: IP68.  
IP68: 1M depth of water in 24 Hrs.  
(防水等級: IP68)  
IP68: 水深一米測試 24 小時
  - \* Shell: Zinc Alloy#3, Ni Plated, Silver.
  - \* Insulation: Nylon, Black.
  - \* Female Pin: Copper Alloy, Silver Plated.
  - \* Gasket: Silicone, Gray.
  - \* Screw: Stainless Steel.
  - \* Recommended Panel Thickness 9mm(Max).

UNIT: mm		
TOLERANCE	.X ±0.25	
.XX ±0.1		
.XXX ±0.05		
ANGLES	±1°	

TITLE PANEL SCREW 12PIN M CONN F PIN			
SCALE 1:1	SIZE A4	SHEET 1 OF 1	
REV. B	WC-REV. A.2	$\varnothing$ : Inspection item	

**Amphenol LTW**  
安費諾亮泰企業股份有限公司

ITEM NO. LD20-12PMFS-SW8001	DRAWN BY Vicky	DATE 2016-05-04
DWG NO. LD20-12PMFS-SW8001	CHECKED BY Rita	DATE 2016-05-04
CUSTOMER ALTW	APPROVED BY Lisa	DATE 2016-05-04

THIS DOCUMENT IS SUBJECT TO CHANGE WITHOUT NOTICE. IT IS CONFIDENTIAL AND A PROPERTY OF Amphenol LTW. DISCLOSURE TO THIRD PARTY HAS TO BE AUTHORIZED BY Amphenol LTW.