

THIS DOCUMENT IS SUBJECT TO CHANGE WITHOUT NOTICE. IT IS CONFIDENTIAL AND A PROPERTY OF AMPHENOL LTW. DISCLOSURE TO THIRD PARTY HAS TO BE AUTHORIZED BY AMPHENOL LTW.

REV.	ECN NO.	DATE	SIGN	DESCRIPTION
A	-	2022/09/08	Scott	Rev.03 To Rev.A

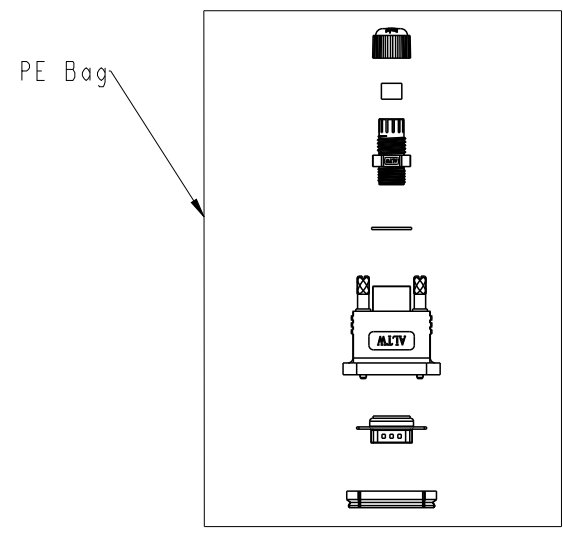
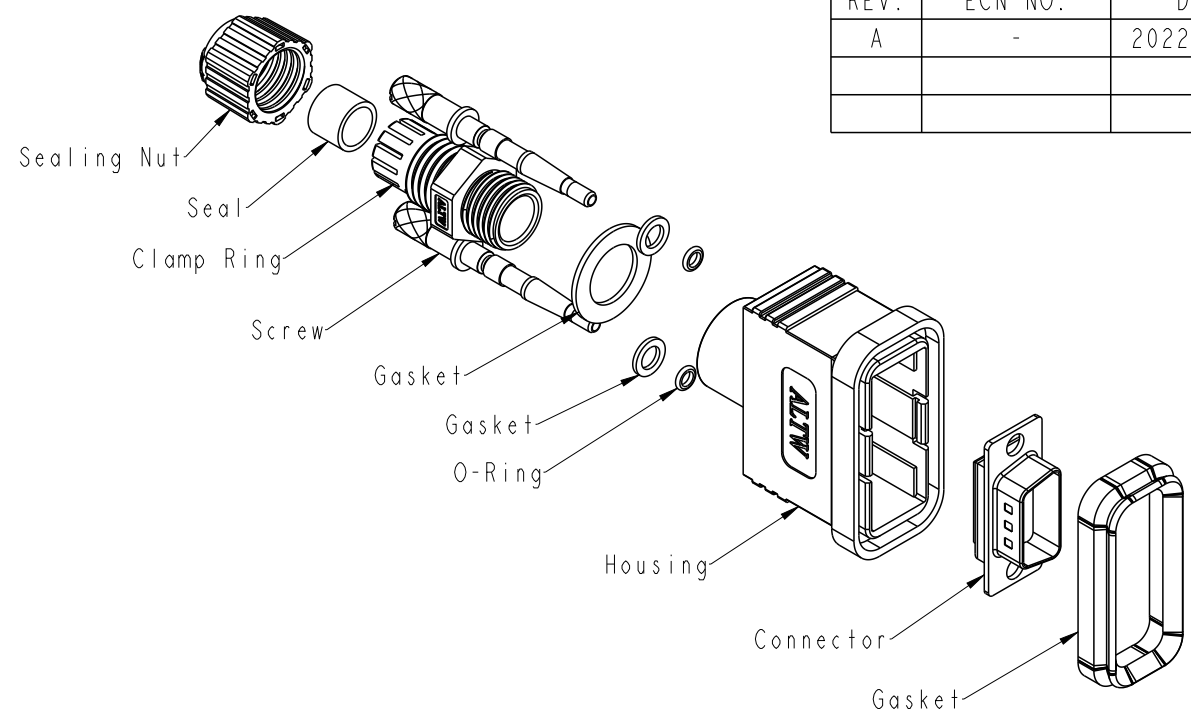

Note:

- * RoHS Compliant
- * \varnothing Important Dimension
- * Waterproof Rate: IPX7, Mated.
- * Connector
 - Housing: D-SUB, 9Pin, Male.
 - Pin: Copper Alloy, Gold Plated.
 - Gasket: Rubber, Black.
 - Screw: Metal.
 - O-Ring: Rubber, Clear.
 - Seal For Cable OD: $\varnothing 3.5\text{mm} \sim \varnothing 7.0\text{mm}$.
 - Clamp Ring: Termoplastic, Black.
 - Seal: Rubber, Black.
 - Sealing Nut: Termoplastic, Black.
- * One Set Unassembled in One PE Bag.
- * Pins are Purchased Separately, PN:BBA00011222

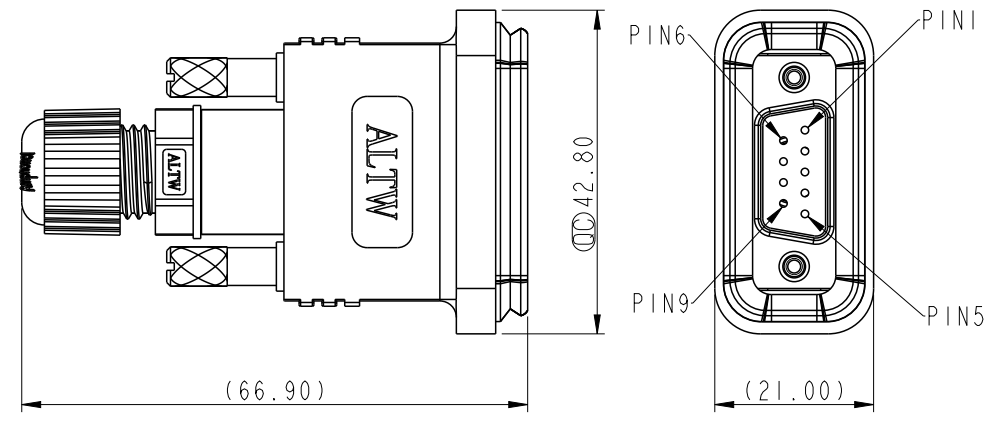

UNIT:mm	\varnothing	\varnothing	TITLE D-SUB, DB SHLD, 09P, CABLE W/O SR M, M, CRIMP, SCREW	
TOLERANCE	$\pm 0.5 \text{ mm}$		SCALE 1:1	SIZE A4
REV. A	WC-REV. A.3	SHEET 1	OF 1	\varnothing : Inspection item

Amphenol LTW
安費諾亮泰企業股份有限公司

ITEM NO SDB-09BMMC-SL7001	DRAWN BY Scott	DATE 2022/09/08
DWG NO SDB-09BMMC-SL7001	CHECKED BY Allen	DATE 2022/09/08
CUSTOMER ALTW	APPROVED BY Neo	DATE 2022/09/08