

REV.	ECN NO.	DATE	SIGN	DESCRIPTION
E	LEN1790195~206	2016/09/10	Lingpeng	Update The Note
F	N180019	2019-03-14	Peng	Add 5 PIN
G	C230888	2023/06/15	He long	△G *3

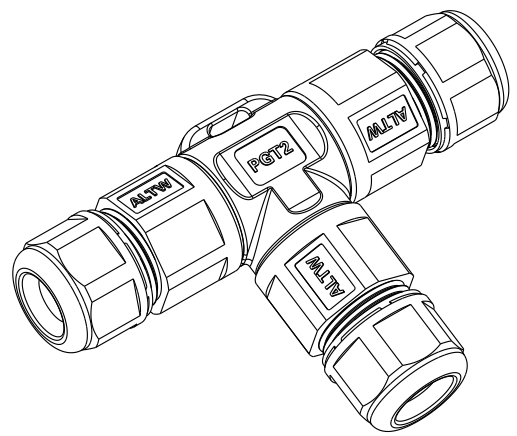

**ALTW**  
**CONFIDENTIAL**  
 2019-03-14  
**R&D DEPT.**

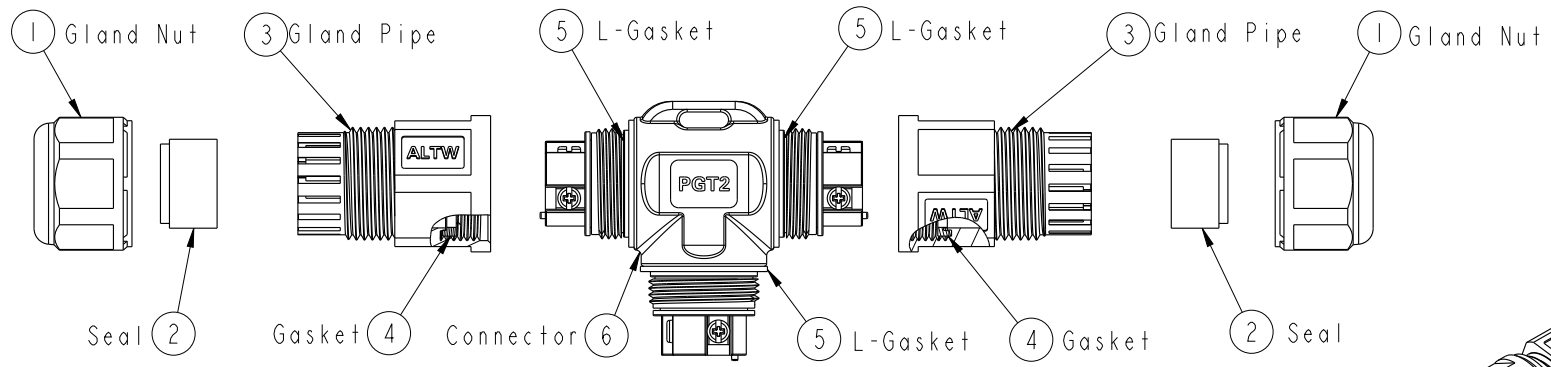
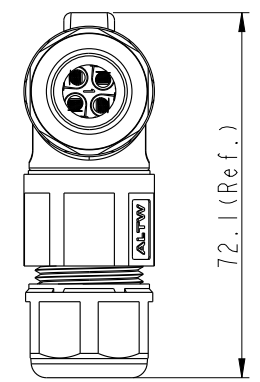
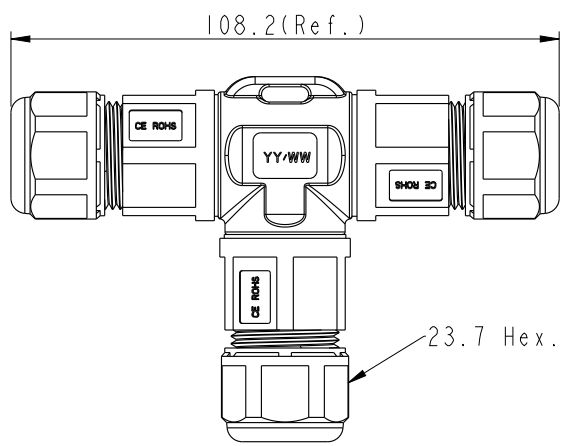
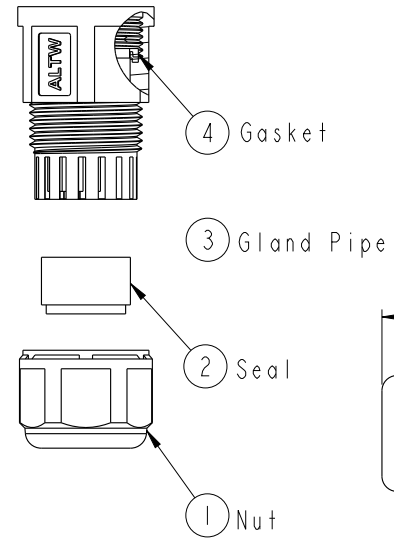
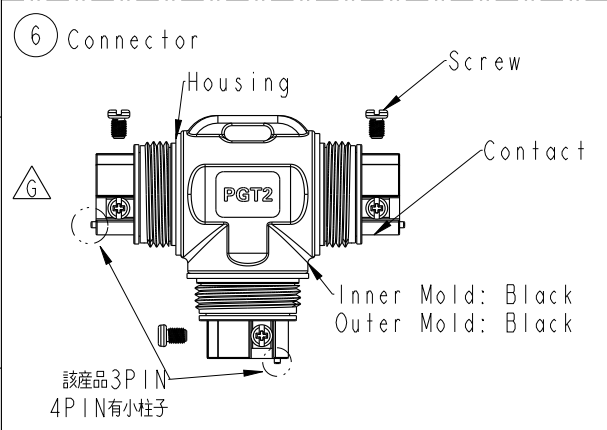

UNIT: mm TOLERANCE ±0.5mm	TITLE PGT2 Cable Joiner Screw-in Type			<h1 style="text-align: center;">Amphenol LTW</h1> <p style="text-align: center;">安費諾亮泰企業股份有限公司</p>	ITEM NO	DRAWN BY Peng	DATE 2019-03-14
	SCALE 67:100	SIZE A4	SHEET 1 OF 2		DWG NO SC-L-PGT2-XX-XX	CHECKED BY Ma Fei	DATE 2019-03-14
REV. G	WC-REV. .0	◎◎: Inspection item	CUSTOMER ALTW	APPROVED BY Jerry	DATE 2019-03-14		

THIS DOCUMENT IS SUBJECT TO CHANGE WITHOUT NOTICE. IT IS CONFIDENTIAL AND A PROPERTY OF AMPHENOL LTW. DISCLOSURE TO THIRD PARTY HAS TO BE AUTHORIZED BY AMPHENOL LTW.

THIS DOCUMENT IS SUBJECT TO CHANGE WITHOUT NOTICE. IT IS CONFIDENTIAL AND A PROPERTY OF Amphenol LTW. DISCLOSURE TO THIRD PARTY HAS TO BE AUTHORIZED BY Amphenol LTW.

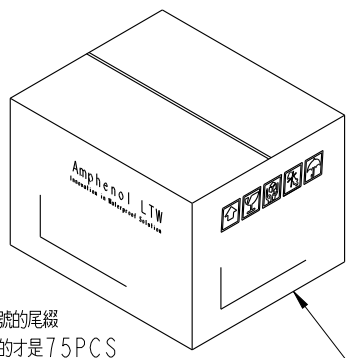
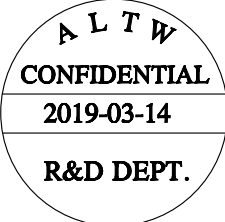

9 Carton

QTY: 75PCS

7 PE Bag

8 Instruction

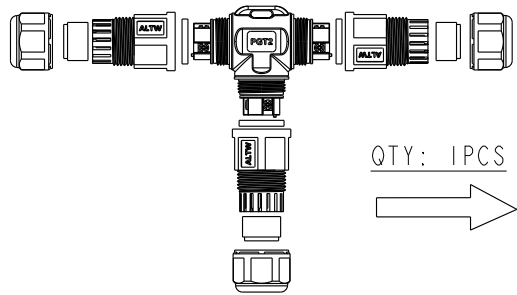
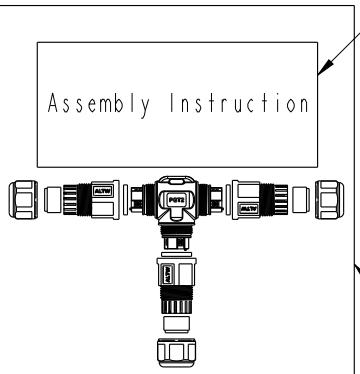

QTY: 1PCS



Both A Unassembled product And An Instruction Are In A PE Bag.  
(將一套未組裝的產品和說明書，放置於一個PE袋，並封口)

SC-L-PGT2-XX-XX  
L: Cable Joiner  
Type: PGT2

Seal's Color: BL-Blue(藍色) For Cable Range:  $\varnothing 4.5\sim\varnothing 6.5\text{mm}$   
 YW-Yellow(黃色) For Cable Range:  $\varnothing 6.5\sim\varnothing 8.5\text{mm}$   
 GN-Green(綠色) For Cable Range:  $\varnothing 8.5\sim\varnothing 10.5\text{mm}$   
 RD-Red(紅色) For Cable Range:  $\varnothing 10.5\sim\varnothing 12.5\text{mm}$   
 AA-All Seals For Cable Range:  $\varnothing 4.5\sim\varnothing 12.5\text{mm}$

No. of Conductor: 02-2Poles  
 03-3Poles  
 04-4Poles  
 05-5Poles

**G**  
圓柱表示產品有小柱子，沒有標註的PIN表示產品沒有小柱子

- Note: **F**
- \* **(C)** Important Dimension To Check.
  - \* Waterproof Rate: IP68 (50M,24H)
  - \* Housing: PA66+GF, Black.
  - \* Gland Nut: PA6+GF, Black.
  - \* Gland Pipe: PA66, Black.
  - \* Contact: Brass, Nickel Plated
  - \* Gasket & L- Gasket : Silicone, Yellow.
  - \* Seal: Silicone, Blue & Yellow & Green & Red.
  - \* Rated Voltage: 2~4 Pole 450V AC
  - \* Rated Current: 2 & 3 Pole Max. 20A ,  
 4 Pole Max. 15A.  
 5 Pole Max. 10A.
  - \* Operating Temperature:  $-40^{\circ}\sim+105^{\circ}$ .
  - \* Gland Pipe Recommended Tightening Torque:  
 8~10 Kgf.cm(0.78~0.98 N.m)
  - \* Gland Nut Recommended Tightening Torque:  
 8~10 Kgf.cm(0.78~0.98 N.m)
  - \* Seal For Cable OD:  $\varnothing 4.5\sim\varnothing 6.5\text{mm}$ , Blue.  
 $\varnothing 6.5\sim\varnothing 8.5\text{mm}$ , Yellow.  
 $\varnothing 8.5\sim\varnothing 10.5\text{mm}$ , Green .  
 $\varnothing 10.5\sim\varnothing 12.5\text{mm}$ , Red.
  - \* Screws for Wire connection recommended tightening torque: 2.00~4.50kgf.cm / 0.196~0.44 N.m
  - \* Applicable Wire gauge (Stranded wire cross section)  
 2~4Pole:  $0.75\text{mm}^2$  (18AWG) ~  $2.5\text{mm}^2$  (14AWG)  
 5Pole:  $0.5\text{mm}^2$  (20AWG) ~  $1.5\text{mm}^2$  (16AWG)

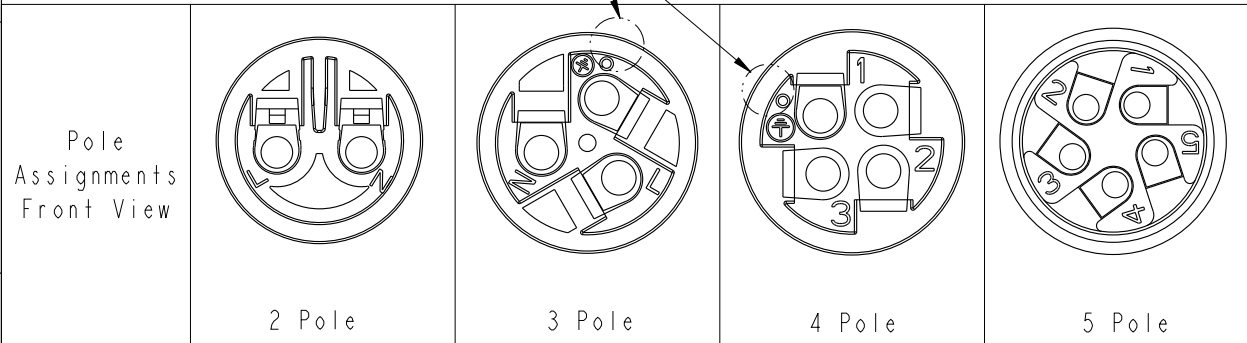

UNIT:mm		TITLE PGT2 Cable Joiner Screw-in Type	
TOLERANCE $\pm 0.5\text{mm}$	SCALE 67:100	SIZE A4	SHEET 2 OF 2
	REV. G	WC-REV. .0	<b>(C)</b> : Inspection item

**Amphenol LTW**  
安費諾亮泰企業股份有限公司

ITEM NO	DRAWN BY Peng	DATE 2019-03-14
DWG NO SC-L-PGT2-XX-XX	CHECKED BY Ma Fei	DATE 2019-03-14
CUSTOMER ALTW	APPROVED BY Jerry	DATE 2019-03-14