

THIS DOCUMENT IS SUBJECT TO CHANGE WITHOUT NOTICE. IT IS CONFIDENTIAL AND A PROPERTY OF AMPHENOL LTW. DISCLOSURE TO THIRD PARTY HAS TO BE AUTHORIZED BY AMPHENOL LTW.

REV.	ECN NO.	DATE	SIGN	DESCRIPTION
I	C230126	2023/02/01	Arvin Chan	△ XI
J	C231052	2023/08/11	Jack Liu	△ J XI
K	C240391	2024/04/30	JC Chen	△ K XI0

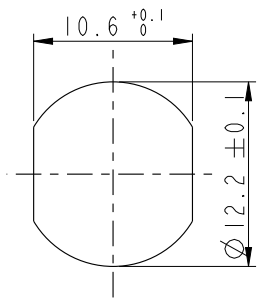

Recommended Panel Cut-Out

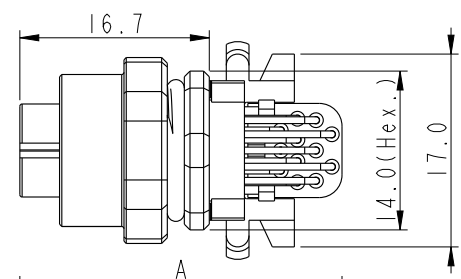

MSAS-XXPFFR-SF7003

XX: No. Of Pin

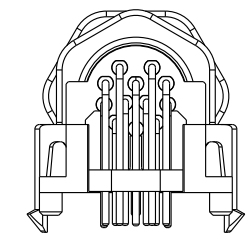
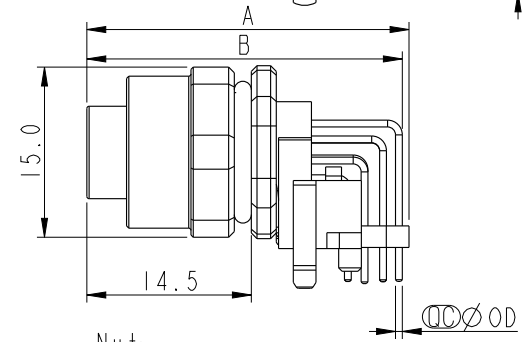
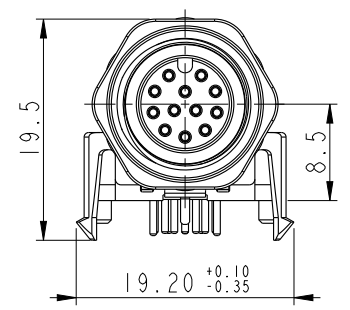

MSAS-03PFFR-SF7003	26.6	25.5	1.0
MSAS-04PFFR-SF7003	26.6	25.5	1.0
MSAS-05PFFR-SF7003	26.6	25.5	1.0
MSAS-06PFFR-SF7003	26.4	25.7	0.8
MSAS-08PFFR-SF7003	26.4	25.7	0.8
MSAS-12PFFR-SF7003	28.4	27.8	0.6
Item No.	A	B	OD

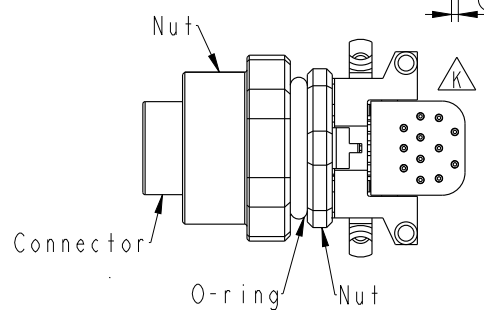

- Note:
- * RoHS Compliant
 - * \varnothing Important dimension
 - * Waterproof rate: IP67, mated
 - * Connector Housing: Thermoplastic, Black
 - * Pin: Copper alloy, Gold plated
 - * Nut: Metal
 - * O-Ring: Rubber, Gray
 - * For panel thickness max: 3.0mm
 - * For pcb thickness max: 1.6mm
 - * Connector nut is packed separately in pe bag

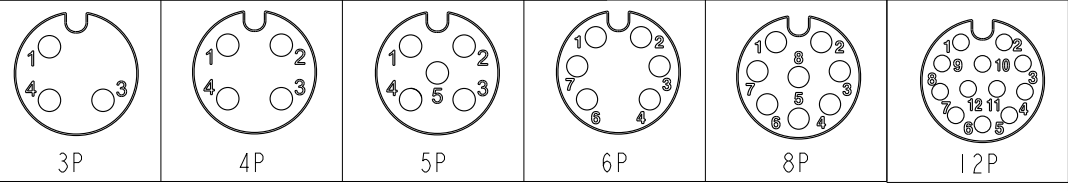

Pin Assignment Front View

UNIT: mm			TITLE N SEN, M12 A -SHLD, SCREW RECEPTACLE, F, F, PCB R
TOLERANCE .X ±0.25 .XX ±0.1 .XXX ±0.05 ANGLES ±1°	SCALE 3:2	SIZE A4	SHEET 1 OF 3
	REV. K	WC-REV. A.3	\varnothing : Inspection item

Amphenol LTW
安費諾亮泰企業股份有限公司

ITEM NO.	DRAWN BY JC Chen	DATE 2024-05-06
DWG NO. MSAS-XXPFFR-SF7003	CHECKED BY Jerry	DATE 2024-05-06
CUSTOMER ALTW	APPROVED BY Fred	DATE 2024-05-06

THIS DOCUMENT IS SUBJECT TO CHANGE WITHOUT NOTICE. IT IS CONFIDENTIAL AND A PROPERTY OF Amphenol LTW. DISCLOSURE TO THIRD PARTY HAS TO BE AUTHORIZED BY Amphenol LTW.

2 3 4 5 6 7 8

F

E

D

C

B

A

12Pin View

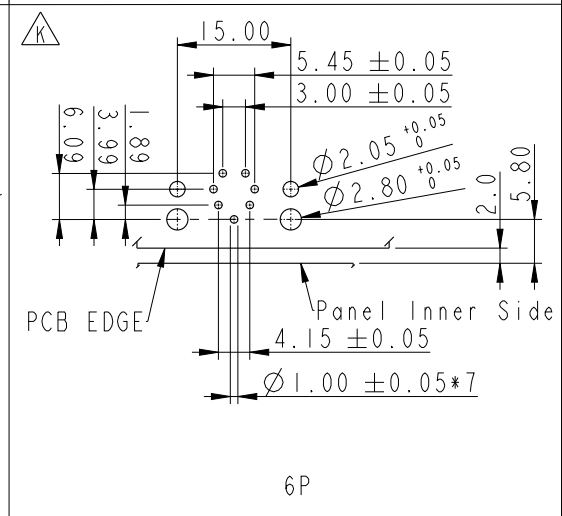
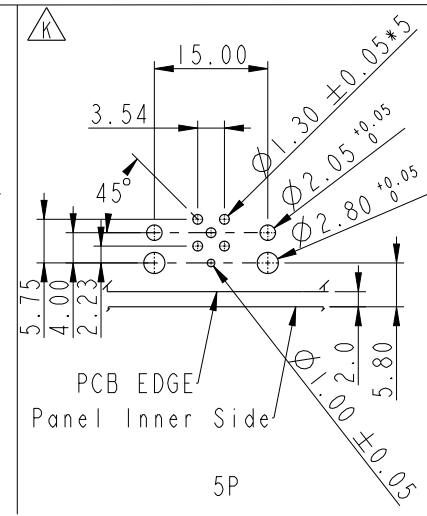
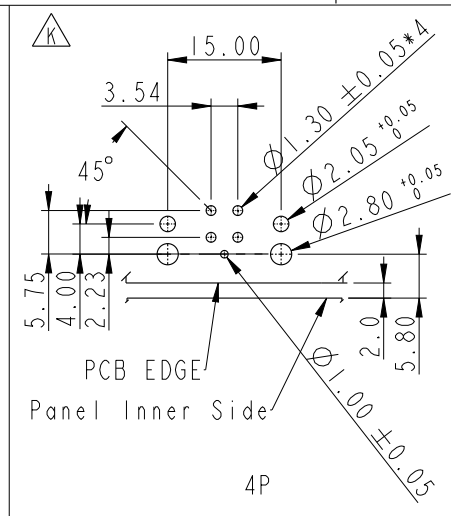
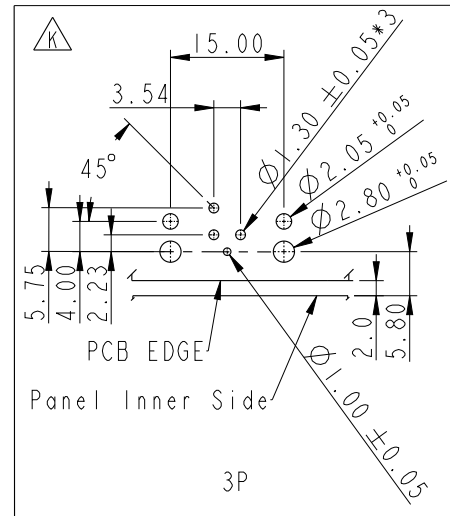
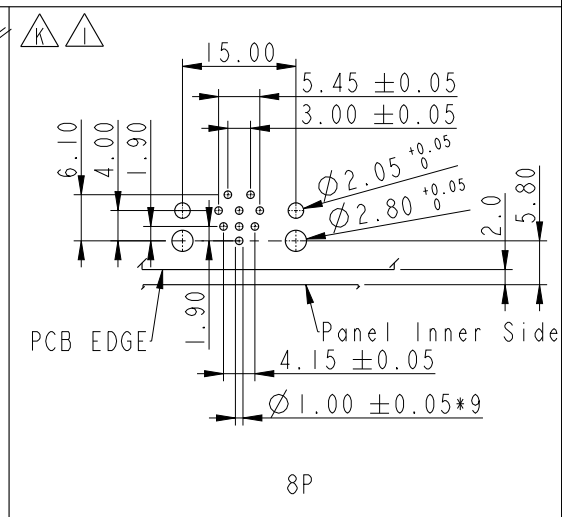
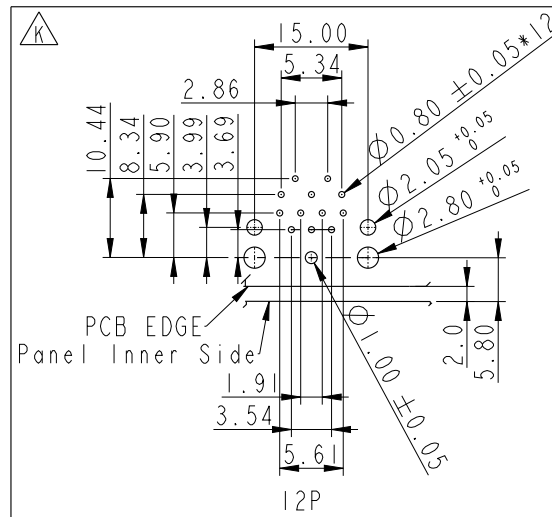

PCB Layout

UNIT: mm		
TOLERANCE	.X ±0.25	
	.XX ±0.1	
	.XXX ±0.05	
ANGLES	±1°	

TITLE N SEN, M12 A -SHLD, SCREW RECEPTACLE, F, F, PCB R		
SCALE 3:2	SIZE A4	SHEET 2 OF 3
REV. K	WC-REV. A.3	

Amphenol LTW
安費諾亮泰企業股份有限公司

ITEM NO	DRAWN BY JC Chen	DATE 2024-05-06
DWG NO MSAS-XXPFFR-SF7003	CHECKED BY Jerry	DATE 2024-05-06
CUSTOMER ALTW	APPROVED BY Fred	DATE 2024-05-06

2 3 4 5 6 7 8 W10814-03-0001A2

THIS DOCUMENT IS SUBJECT TO CHANGE WITHOUT NOTICE. IT IS CONFIDENTIAL AND A PROPERTY OF Amphenol LTW. DISCLOSURE TO THIRD PARTY HAS TO BE AUTHORIZED BY Amphenol LTW.

F	2	3	4	5	6	7	8			
E										
D										
C										
B										
A	UNIT : mm 		TITLE N SEN, M12 A -SHLD, SCREW RECEPTACLE, F, F, PCB R		<h1 style="margin: 0;">Amphenol LTW</h1> <p style="margin: 0;">安費諾亮泰企業股份有限公司</p>		ITEM NO MSAS-XXPFFR-SF7003	DRAWN BY JC Chen	DATE 2024-05-06	
	TOLERANCE .X ±0.25 .XX ±0.1 .XXX ±0.05 ANGLES ±1°		SCALE 1:1	SIZE A4	SHEET 3 OF 3	REV. K	WC-REV. A.5	CUSTOMER ALTW	CHECKED BY Jerry	DATE 2024-05-06
			(QC): Inspection item				APPROVED BY Fred	DATE 2024-05-06	8 W10814-03-001A2	